

# **STEAMROLLER LINT CONDITIONER AND ELECTRIC BANJO**

**Neil Turner and Samuel Jackson  
Samuel Jackson, Inc.  
Lubbock, TX**

## **Abstract**

Samuel Jackson, Inc. has dedicated itself to the control of moisture in cotton for over 40 years. During the past few years it has developed two new products for this purpose, the Steamroller Lint Conditioner and the Electric Banjo for fans. This paper will introduce these products to those who are unfamiliar with them, and for those that have heard of these products it will provide an update on their progress.

## **Steamroller Lint Conditioner**

### **Introduction**

Many of the benefits of restoring moisture to the cotton fiber after ginning and before packaging have been known for decades. However, as cotton gins have become faster, the need for adding moisture to lint has become more important. This increased need for restoring moisture has created a problem for many gins, because adding moisture at higher ginning rates is much more difficult.

To bridge the gap between the desired bale moisture and the lower moistures achieved by other moist air applicators, Samuel Jackson, Inc. has developed the Steamroller Lint Conditioner System.

### **Design Objectives**

The Steamroller fulfills three objectives.

The first objective is to have a moist air device that can add as much moisture as desirable so automatic control will be justified. Moist air has traditionally been applied to lint fiber in three ways, with a Lint Slide Grid, directly into the battery condenser, or injecting the moist air into the lint flue riser before the battery condenser. While each of these methods has had some success in adding moisture to the fiber, none is capable of consistently adding as much moisture as desired.

The second objective is to eliminate typical problems associated with other methods of humidifying lint cotton. Moisture condensation is the most common of these problems. Since all of the other methods allow warm moist air to mix with cooler ambient air, some of the moisture in the humid air will condense and collect on places where cotton lint is present. This results in the hairing of battery condenser screens or the batt sticking to the lint slide.

The third objective is to compress the batt, which increases the lint slide capacity and allows more cotton to enter the press box at each stroke of the tramper. This is a necessity for high-capacity gins.

### **Concept and Design**

The Steamroller is positioned between the battery condenser and the lint slide (see figure 1). After the cotton comes out of the battery condenser, it is fed into the Steamroller by a large, perforated screen drum. The cotton enters the Steamroller on top of a stationary perforated screen. Moist air from a Humidair Unit enters the plenum chamber at the base of the Steamroller. This moist air passes up through the stationary screen and penetrates the batt. All of the moist air is forced evenly through the batt, resulting in a uniformly moisturized batt of cotton. A single roller serves to both doff the cotton off the drum and to compress the cotton into a thin batt of conditioned cotton upon leaving the Steamroller. The used air from this process is evacuated from the top of the Steamroller and typically added to the air in the lint flue riser.

Seals at the entrance and exit of the Steamroller reduce cold air leakage. With very little cold air leakage, the temperature inside the Steamroller remains the same as the temperature of the humid air. The result is less condensation and fewer problems associated with condensation.

Due to the ability to add high amounts of moisture, the moist air generator must have fast-responding, but stable temperature control. For this reason, every Steamroller Lint Conditioning System uses a PLC-controlled Samuel Jackson Humidaire Unit to generate moist air. Using this Humidaire Unit is a key element in achieving consistent moisture levels.

Each gin has a different layout and each gin manager has different concerns. The Steamroller System is not a one size fits all solution. To address these differences, every system is carefully engineered to meet the requirements of each installation.

The resulting success of the Steamroller Lint Conditioning System is due to the ability of the Steamroller to effectively add moisture to fiber, a tightly controlled humid air supply, and an engineered system layout.

## **Results**

The first Steamroller was installed at the end of the 1996 gin season at Rayville Producers Gin in Rayville, LA. Due to the timing of the installation, the testing was limited to approximately 100 bales. While the duration of this test was not long enough to evaluate long-term use or operation under varying conditions, the performance results were so encouraging that it was decided to expand the number of installations to a limited number of sites.

In 1997, four more installations were added. These sites were chosen in part to test the performance and operation of the Steamroller in different conditions. Griffin Gin in Elaine, AR provided the opportunity to test the Steamroller in another high capacity gin, similar to Rayville Producers Gin. Another Steamroller was installed in Cotton Center Farmers Coop Gin in Cotton Center, TX, which gins stripper harvested cotton. Installations were also located at Farmers Gin Co. in Buckeye, AZ and at Lee Wilson & Co. Gin in Wilson, AR. These last two installations provided the opportunity to test the Steamroller in medium capacity gins in two very different environments.

In the 1997 gin season, these five gins with Steamroller installations ginned a combined total of 196,500 bales. The overall results from the Steamroller's first full season of operation were very positive. Each gin effectively demonstrated the primary objective of consistently adding desired levels of moisture. Some of the installations experienced an overall increase in ginning rate, by taking advantage of the Steamroller's batt compression. In addition to these benefits, many of the traditional problems from moist air applications were eliminated. These installations also provided the feedback to evaluate the Steamroller for everyday operation under varying conditions. This feedback was the basis for some small, but necessary design changes. During the summer of 1998, each of the five installations were retrofitted with the design modifications.

Also in 1998, six more installations were added (see table 1 for a complete list of Steamroller Systems). Installations now totaled 11 Steamrollers in seven states. The total number of bales moisturized by the Steamroller in 1998 is projected to be 336,700 bales (see table 2). The design modifications proved to be successful in eliminating or preventing the problems experienced in 1997.

One of the gins operating a Steamroller in 1998 was also equipped with a data logging system. Part of the data logging system was dedicated to monitoring the performance and operation of the Steamroller System. Statistical analysis of this data has just begun, but some of the results are already available.

Bale moisture was measured using a Malcam microwave moisture sensor. This data was logged for 27,845 bales and the distribution for the bale moisture is shown in figure 2. For the data collected the average bale moisture was 8.2% with a standard deviation of 0.7%. The average moisture content before the Steamroller was 5.1% with a standard deviation of 0.5%.

Data was also collected for other variables, which impact the ability to restore moisture to the fiber. Figure 3 shows the Steamroller System performance by plotting the after-drying moisture and bale moisture for each bale ginned for an entire day. This graph demonstrates the consistent ability to add the desired amount of moisture. Figure 4 shows

the Humidair air and water temperatures from the same day. If more moisture had been desired, the water temperature could have been raised closer to the air temperature.

Referring back to the original design objectives, the Steamroller has demonstrated the ability to add more moisture to the fiber than any other moist air device. Condensation problems have been dramatically reduced by avoiding a mix of cold air with warm humid air. Finally, the compression ability of the Steamroller has benefited every installation.

### **Steamroller Benefits**

As mentioned in the introduction of the Steamroller section of this paper, restoring moisture to cotton lint has many benefits. These include benefits to the cotton producer, the cotton gin, and the textile mill.

Cotton producers benefit from the Steamroller by its ability to restore moisture to the fiber. When seed cotton is brought to the gin for processing, it typically must be dried. This drying is necessary to properly clean the cotton before it is ginned. Some, if not all of the moisture lost during drying, can be restored by the Steamroller.

There are many benefits a cotton gin can enjoy from a Steamroller. As mentioned earlier, batt compression can increase lint slide capacity and charger capacity. This alone can increase the production capacity of a gin. Moisturized lint is also easier to press, requiring dramatically less hydraulic pressure to produce a bale. This ability to press out bales at lower ram pressures has several advantages, including less press wear, faster press operation, a lower demand on booster pumps, and the ability to produce consistent and higher bale weights.

Dry cotton bales can cause many problems for textile mills. Broken bale ties make storing and handling bales difficult. In the opening room, dry bales can spring high above the other bales and even topple over. Bales of cotton that have been moisturized have less tie breakage and are easier to control in the opening room. Textile mills may benefit from moisture conditioned cotton in other ways as well. It has long been speculated that moisture conditioning at the press may improve the spinning properties of the fiber. Currently, several independent studies are being made to test the influence of moisture on spinning.

### **Conclusion**

Based on the positive results from development and testing, the Steamroller has officially become a part of the Samuel Jackson product line. The Steamroller installation base will continue to expand in the United States and possibly extend internationally. During this time, research will continue in the analysis of performance data and in spinning quality tests.

## **Electric Banjo**

### **Introduction**

There is a problem in the use of centrifugal fans in cotton handling systems. These fans use the most power when they are not doing the least useful work.

Under normal circumstances in a cotton gin, a fan's speed and motor horsepower are determined by the maximum load of the fan. This maximum load occurs when there is no cotton in the system and the air it moves is cold. When the air is heated and cotton is being ginned, the fan motor load falls dramatically, sometimes to 60% of the maximum. This means that the investment in the fan, motor and starter is largely wasted. Because less cotton can be handled per hour, per-bale costs for labor, electric power and fuel all increase. The Electric Banjo turns this situation around and enables the fans to operate at their maximum capability when needed. When not needed, as when cotton is not being ginned, the Banjo can unload the fans and save power.

## **Design Objectives**

Other industries have implemented fan dampeners on clean air applications to control airflow volumes and power consumption. These devices restrict airflow or induce a swirl in the inlet of a fan by manipulating a series of vanes. In many instances, a modulating device automatically adjusts these vanes. The traditional fan dampeners work well for clean air, but are not suitable for cotton handling systems, as the trash and lint entrained in the air would prevent the vanes from working properly.

The primary objective is to develop a device based on the principles of fan dampeners, but modified to tolerate the trash present in cotton air handling systems. Automatic control of the device is necessary to maintain a constant motor load, as conditions in the system can change dramatically. A constant motor load with a constant fan speed yields a constant air volume, resulting in maintaining the desired air volumes independent of cotton loading rates.

As mentioned earlier, an important design objective is the ability to operate with trash-laden air. There are two main concerns caused by the trash. The first concern is preventing the trash from interfering with normal operation by avoiding places where trash can jam a moving part or restrict airflow. The second concern is minimizing the amount of wear caused by the trash.

The final objective was to package the device with a control system that not only controlled fan motor load, but monitored and alerted users of problems, and interfaced with existing gin controls to minimize power consumption when idling. All of the controls were designed with the idea of making the device easy for the end user to customize for their application. A good diagnostic system allows an early identification of problems, simplifies troubleshooting and reduces down time.

## **Concept and Design**

The Electric Banjo is installed at the inlet of the fan (see figure 5). When the fan is operating, air enters the Banjo through the rectangular opening. Once inside the Banjo, a vane directs the air to a specially-designed funnel, which connects to the fan inlet. The combination of the vane and the funnel forces the air to swirl in the direction of the fan's rotation. A linear actuator positions the vane, which determines the amount of swirl induced into the air. Controlling this swirl allows control of the air volume and motor load.

The Banjo is ruggedly constructed to resist wear. Internal assemblies deflect trash from jamming between the vane and the sidewalls. External channels reinforce the Banjo walls, which are subject to high vacuum during operation.

The Banjo control allows the operator to adjust the fan load setpoint. The setpoint is expressed as a percentage of the motor's full load amps. Once the operator has entered the setpoint, the control maintains the motor current by adjusting the vane position. As changes in the system occur, the control automatically moves the vane in response. For instance, an increase in cotton into the system will cause an amperage drop in the fan motor. The Banjo control senses the change in amperage with a current transformer. To compensate for this change, the control will open the vane until the motor current reaches the setpoint. Conversely, if the feed of cotton is stopped, the control will close the vane until the motor current reaches the setpoint.

The Banjo control also senses when the fan is turned off. When this occurs, the Banjo vane is moved to the closed position. It remains at this position until the fan is restarted. By moving the vane to the unloading position, the fan draws less current when started, thus providing a "soft start" on the fan motor.

In addition to controlling the vane position, the Banjo control continually performs diagnostic checks. If a problem is detected with the Banjo or with the air system, the operator is alerted and the problem is displayed on an alphanumeric display. The most recent problems are stored in an error history log, which can display up to 500 errors and alarms with the time and date they occurred.

A setup program allows the user to customize the Banjo control for each application. In this program, the Banjo control can be enabled and fine tuned. This program also allows the user to enter the value for each motor's full load amp rating and provides a means to set the internal clock.

## **Results**

Four Banjos were installed at Jones County Cotton Gin in Trenton, North Carolina in 1997. Two of the Banjos were installed on the first stage pull fans and the other two Banjos on the second stage pull fans. In addition to drying system air, the first stage fans were also handling trash from the stick machines.

During the early part of the season, different algorithms were tested to determine which yielded the best control. The desired control response was achieved. Initially, with the fan off, the vane was in the closed position, allowing a “soft start”. After the fan was started, the control moved the vane until the setpoint was reached. The heaters were then turned on. Normally, heated air would cause the motor load to fall, but the Banjo vane opened until the setpoint was once again reached and maintained. Once cotton began feeding into the system, the Banjo responded by opening its vane, again. As the amount of cotton in the system varied, the Banjo would respond by opening or closing the vane, always maintaining a constant motor load. Once the fans were shut off, the vane returned to the closed position.

At approximately 10,000 bale intervals, the Banjo body and vane were inspected for wear. At the end of the season (more than 50,000 bales), the Banjo had no appreciable wear. Not only had the vanes lasted an entire season, the wear was so minimal they did not require rotating. Surprisingly, when the fans were taken apart, the blast wheels showed minimal wear, even on the fans handling the stick machine trash.

In 1998, these four Banjos were modified with vane position sensors to protect the linear actuators. Also in 1998, an additional Banjo was installed at Harvey Gin in Kinston, North Carolina. At Harvey Gin the Banjo was installed on the first stage pull fan. In previous years, this gin was forced to repair this fan at least once during each season. With the Banjo, the fan made it through the entire season without requiring repairs.

Jones County Gin completed its 1998 season with the same blast wheels that were used for the entire 1997 season. Before the Banjos were installed, this gin typically replaced blast wheels twice a season.

In addition to reduction in fan wear and virtually no wear on the Banjo, data was collected to show the positive effects the Banjos can have as a drying system tool. Figure 6 demonstrates the Banjo’s effect on fan motor load. With the Banjo control disabled, motor load falls as the bales per hour increase. However, when the Banjos are enabled, the motor load remains constant as bales per hour increase. With the Banjos, the drying system maintains a constant airflow, resulting in better drying.

Temperature data was collected to show the impact Banjos can have on drying system performance. Figure 7 shows the distribution for the after mix temperatures of 30,695 bales from a drying system that uses Banjos. The average temperature for this data is 159.9 degrees Fahrenheit, with a standard deviation of 14.8. The Banjos were key components in achieving this high air volume, low temperature drying that is desired by most mills.

## **Electric Banjo Benefits**

The original intent of the Banjo was to create a device that can control the quantity of air through a system. This ability of control has many advantages. The first benefit is reducing the amount of air, and thus motor load, when the system is not doing any work. The Banjo also benefits the system while it is loaded by maintaining a constant air volume. Without the benefit of the Banjo, the air volume delivered by the fan would fall, resulting in decreased performance.

Another advantage of controlling the air volume through a fan is by restricting airflow at starting, which allows the fan motor to “soft start”. Since the fan is not subjected to being full loaded, the motor starts with a lower inductive load. Taking advantage of the idling option can also reduce the load on the motor. The Banjo control accepts a discrete input, which will force the Banjo to an idling position. One use for this option is on an unloading system.

Finally, a benefit enjoyed by the existing Banjo installations is a reduction in fan wear. This benefit was not a design objective, but has been a pleasant surprise. Adding extra life to blast wheels, and more importantly avoiding mid-season repairs can save money and costly down time.

## Conclusion

Samuel Jackson, Inc. has included the Electric Banjo as part of its 1999 product line. Plans for 1999 include integration of the Banjo control with the gin PLC, allowing the gin PLC to command the Banjos to move to an idle position. Future installations will also include cotton unloading systems. Data collection and analysis will continue in attempts to evaluate the Banjo's magnitude of impact on air systems.

Table 1. Steamroller Installation List

Steamroller Installations	
1997	1998
Rayville Producers, LA *	Servico Gin, Courtland, AL
Griffin Gin, Elaine, AR	Griffin Gin, Wabash, AR
Lee Wilson Gin, Wilson, AR	Glenbar Gin, Pima, AZ
Cotton Center Coop, TX	Midkiff Coop Gin, TX
Farmers Buckeye Gin, AZ	Jones County Gin, NC
* 100 Bales Ginned in 1996	Farmers Gin Senath, MO

Table 2. Annual Bales Conditioned By Steamroller

Year	Gins	Bales
1996	1	100
1997	5	196,500
1998	11	336,700
Total		533,300

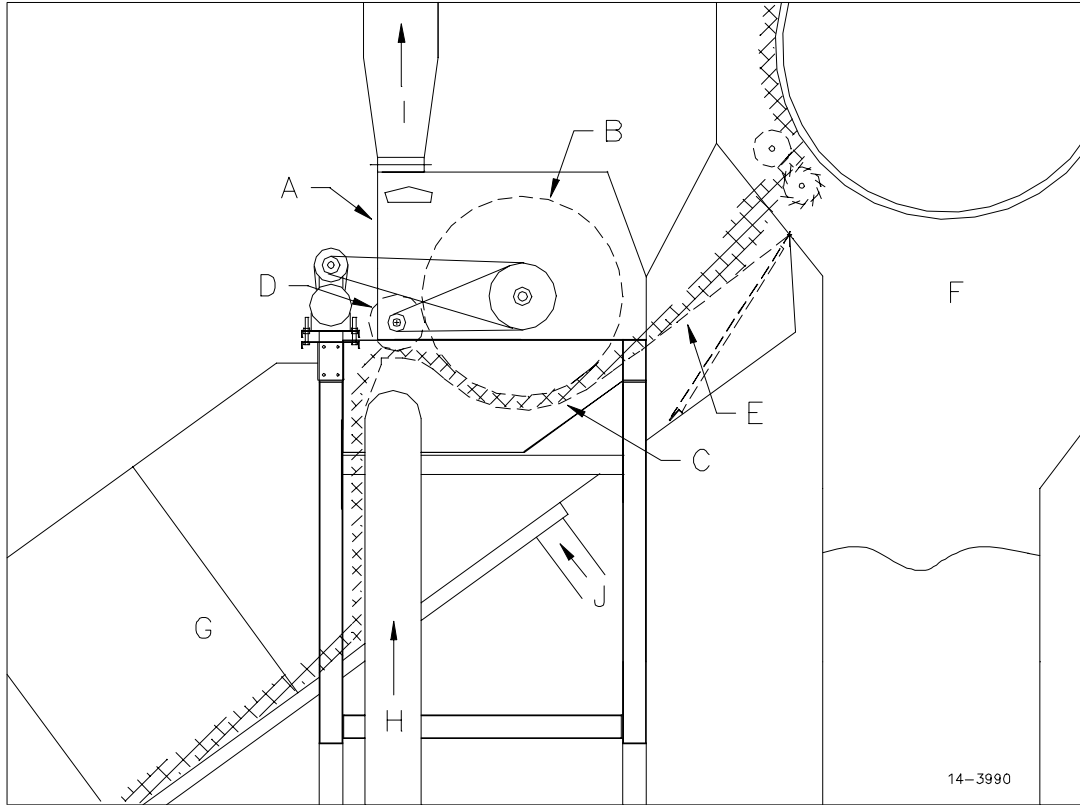

KEY		
A. Steamroller	D. Feed Out Roller	G. Lint Slide
B. Feed In Drum	E. Feed Ramp	H. Moist Air Line
C. Stationary Screen	F. Battery Condenser	I. Pull Air Line

Figure 1 – Steamroller Diagram

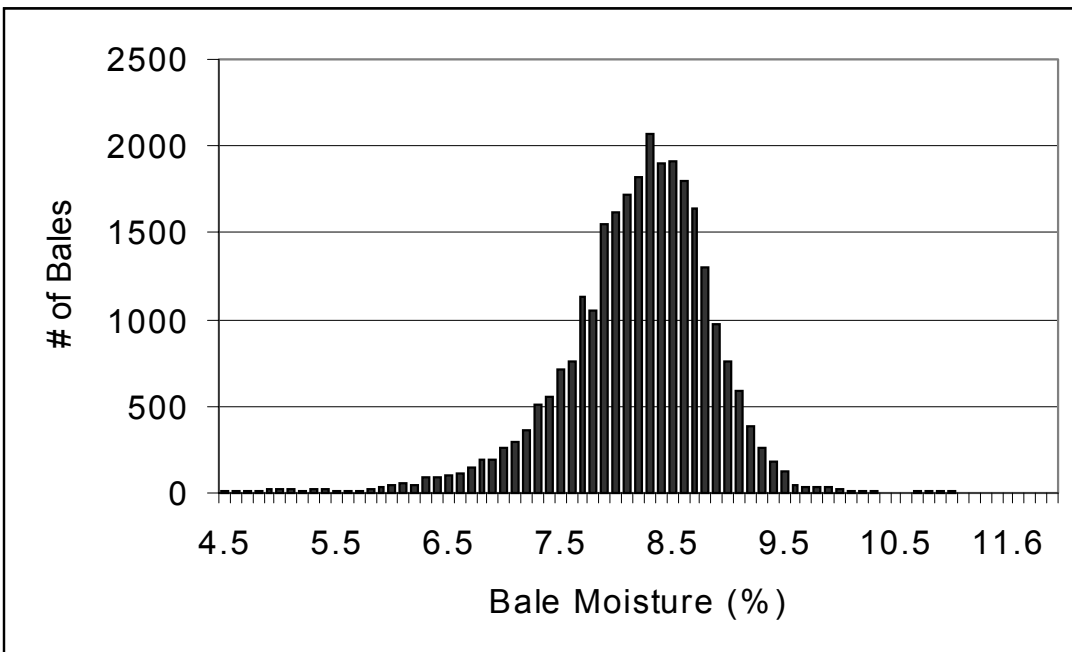

Figure 2 – Bale Moisture Distribution for Steamroller System

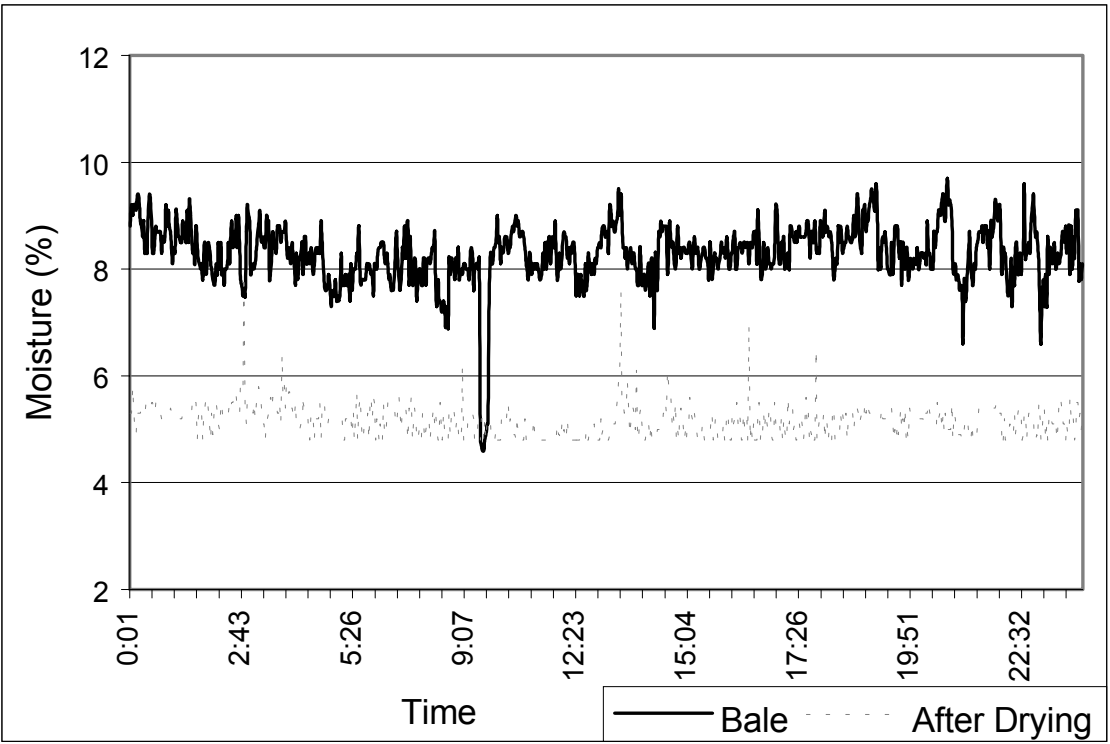

Figure 3 – Moisture Data from One Full Day of Operation

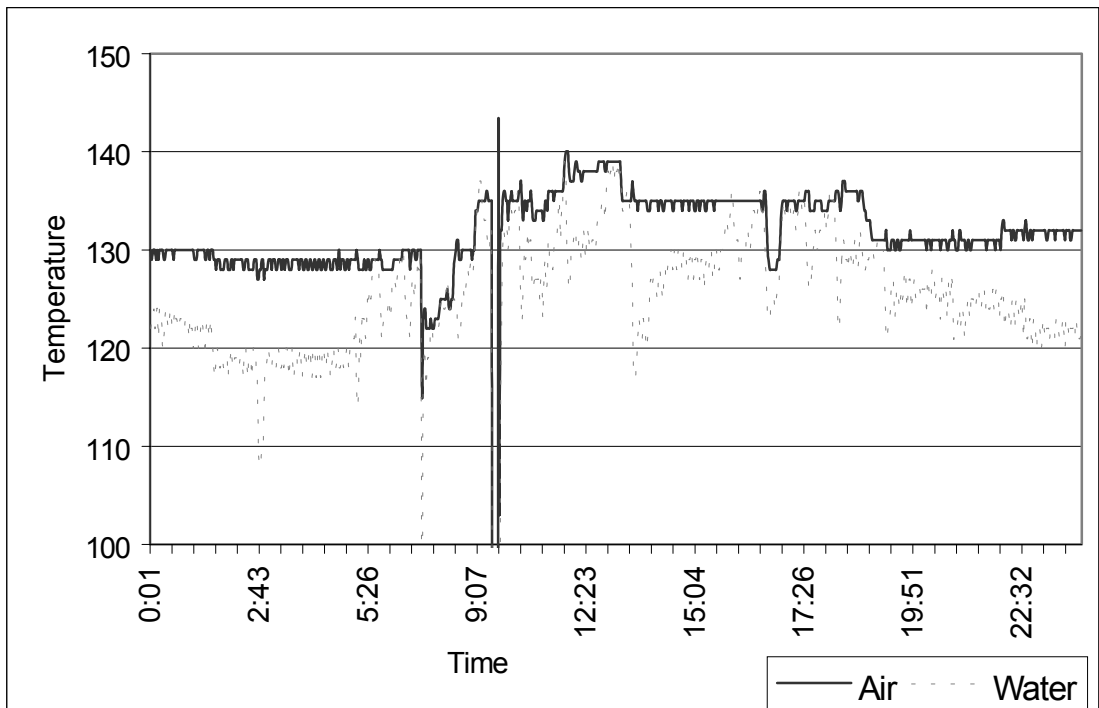

Figure 4 – Humidair Temperatures from One Full Day of Operation

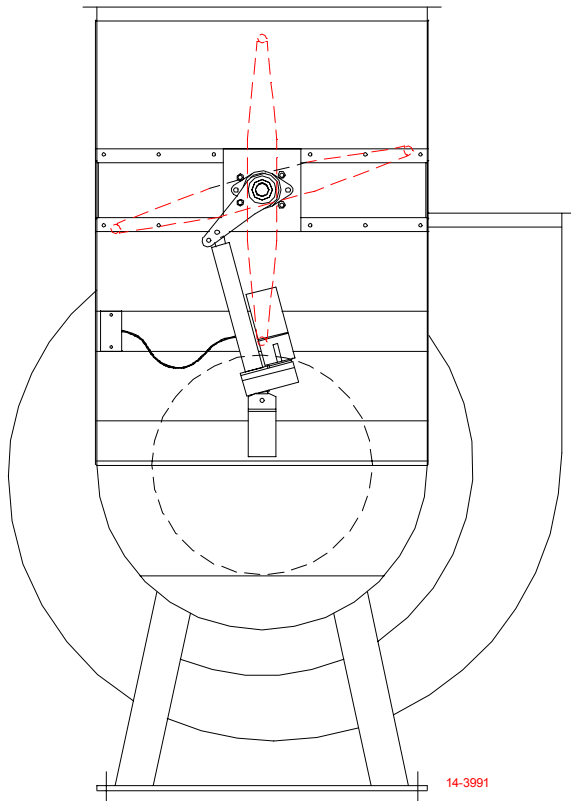

Figure 5 – Banjo Design View

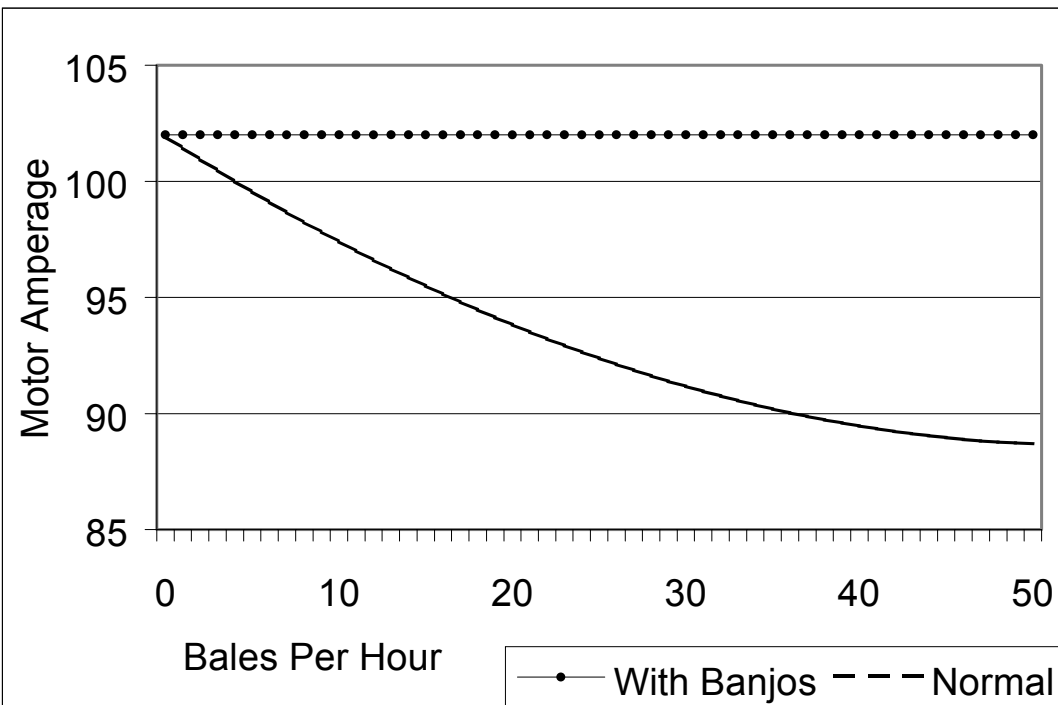

Figure 6 – Effect of Banjos on Motor Amperage as Bales Per Hour Increase

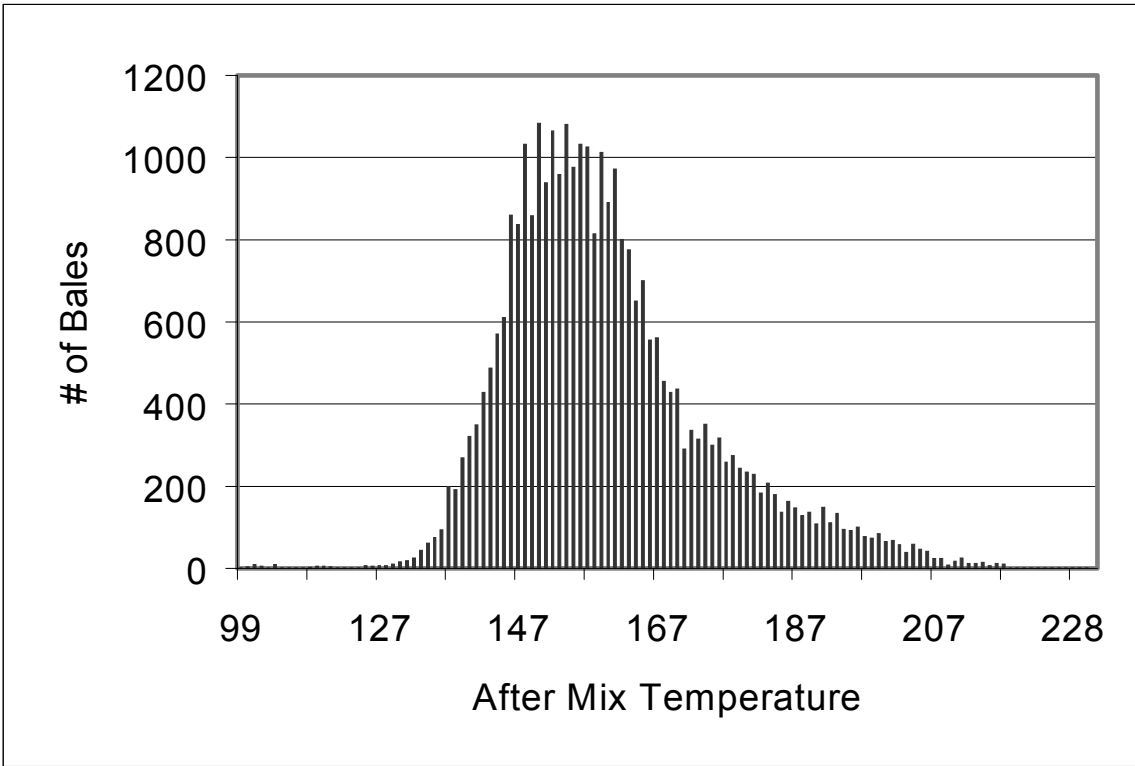

Figure 7 – After Mix Point Temperature Distribution